



# UNIQUE

WOOD PRODUCTS

INTERIOR  
MOULDING & TRIM

[www.uniquewoodproducts.com](http://www.uniquewoodproducts.com)









# INDICE

CEILING	05
CABINET	14
WALL	19
GENERAL PURPOSE	24
WINDOW DOOR	31
FLOOR	46



## Breve historia de la empresa.

Lorem Ipsum es simplemente el texto de relleno de las imprentas y archivos de texto. Lorem Ipsum ha sido el texto de relleno estándar de las industrias desde el año 1500, cuando un impresor (N. del T. persona que se dedica a la imprenta) desconocido usó una galería de textos y los mezcló de tal manera que logró hacer un libro de textos especimen. No sólo sobrevivió 500 años, sino que tambien ingresó como texto de relleno en documentos electrónicos, quedando esencialmente igual al original. Fue popularizado en los 60s con la creación de las hojas "Letraset", las cuales contenian pasajes de Lorem Ipsum, y más recientemente con software de autoedición, como por ejemplo Aldus PageMaker, el cual



# CEILING



Are placed along the wall at the ceiling. They come in a wide range of patterns and sizes. These moulding soften the transition from wall to ceiling while adding a distinctive look and charm to your room.

# UWS51

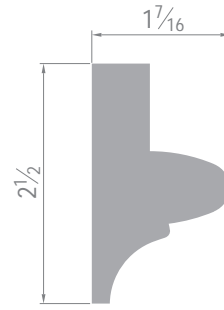

**00S51 - SOLID**

# UW52

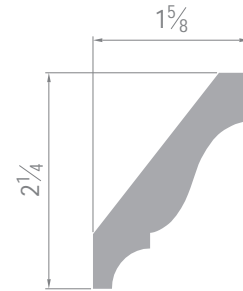

**01052 - FJ**



**04052 - PRIMED FJ**



**00052 - PINE**



**77052 - KA**



**88052 - RED OAK**

# UW51

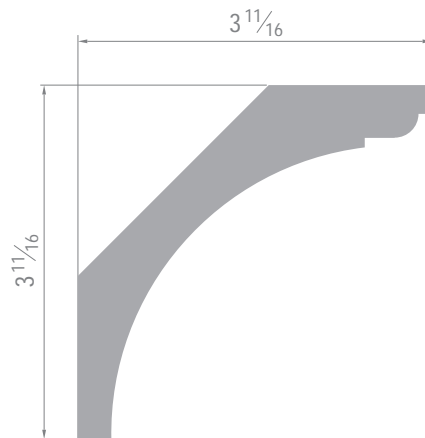

**00051 - PINE**



**04051 - PRIMED FJ**



# UW49

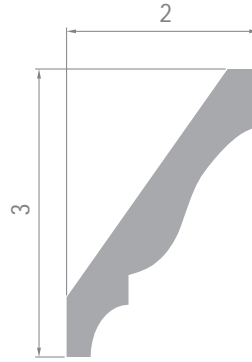

00049 - PIN



01049 - FJ



88049 - RO



85049 - MP



08049 - MDF



05049 - FLEX



04049 - PJF

# UW48

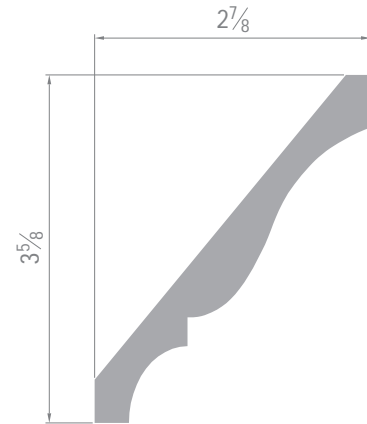

01048 - FJP



85048 - MP



77048 - KA



08048 - MDF



05048 - FLEX

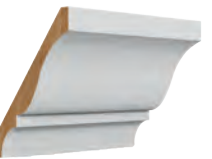

04048 - PFJ

# LA5COLCR

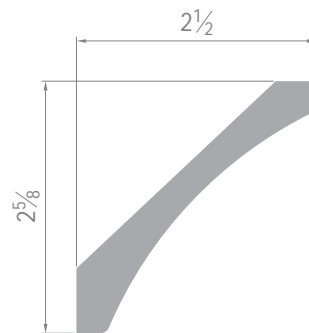

08LA5COLCR - MDF



# UW58

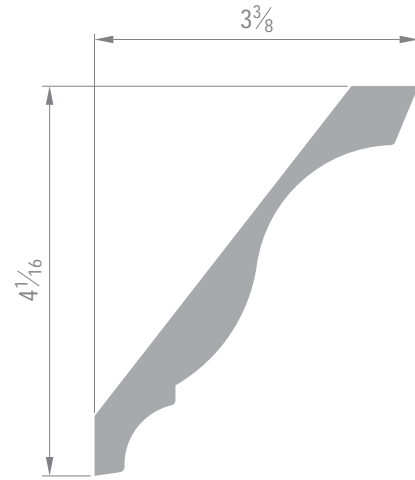

**04058** - PFJ



**01058** - FJP



**00058** - PIN

# CR22

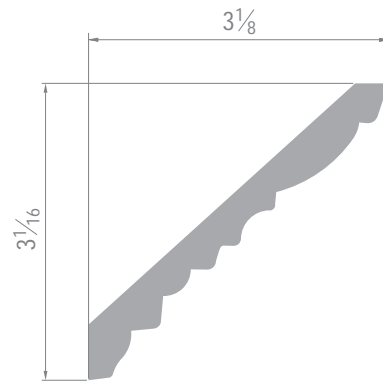

**88022** - MDF



**85022** - MP



**77022** - KA



**05022** - FLEX



**04022** - PFJ



**01022** - FJP

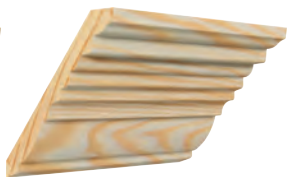

**00022** - PIN

# SUW51

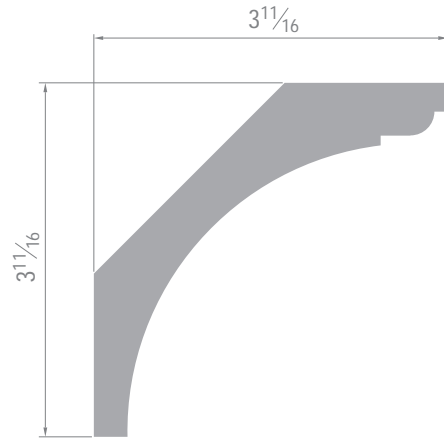

00051 - PIN



05051 - FLEX

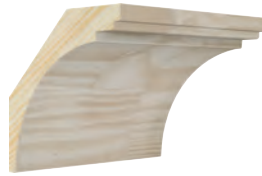

01051 - FJP

# UWBAC

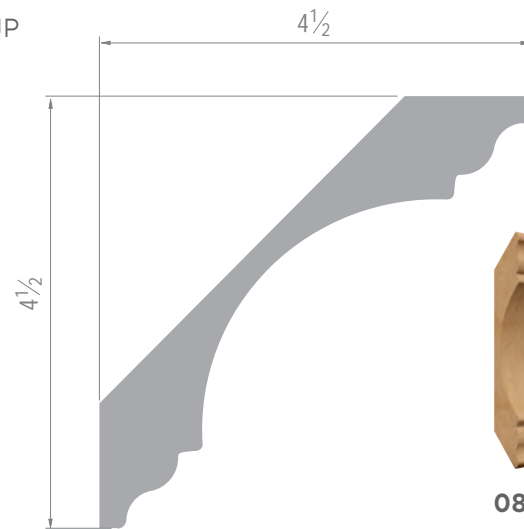

08BAC - MDF

# CR514

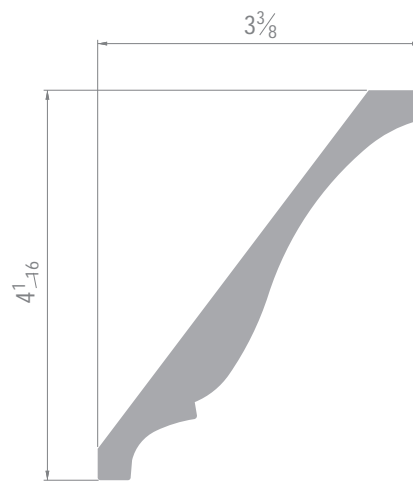

08CR514 - MDF



514DRCR

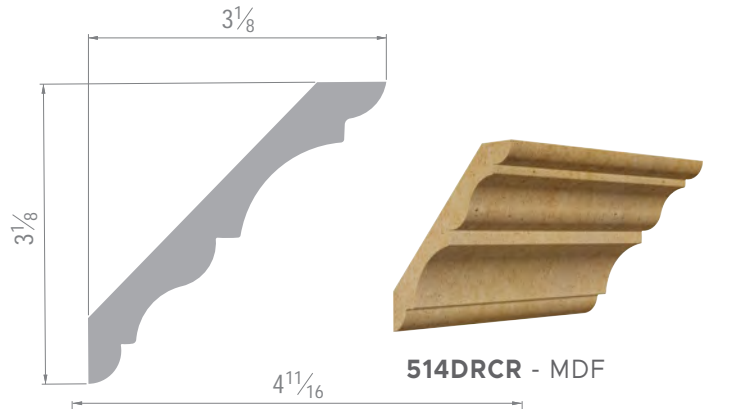

UW310

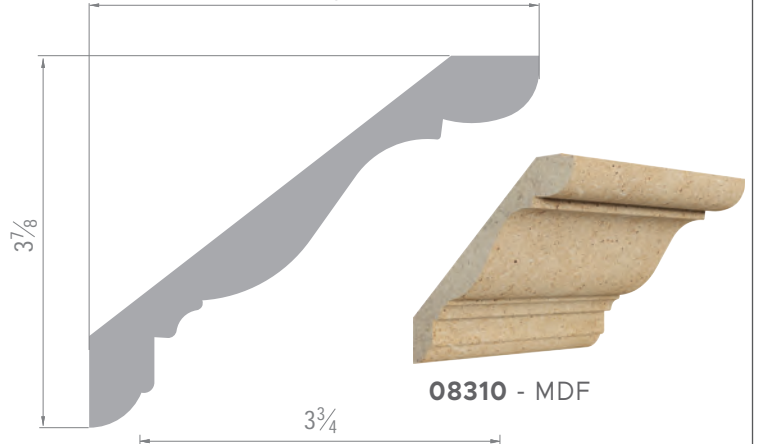

08COLCR

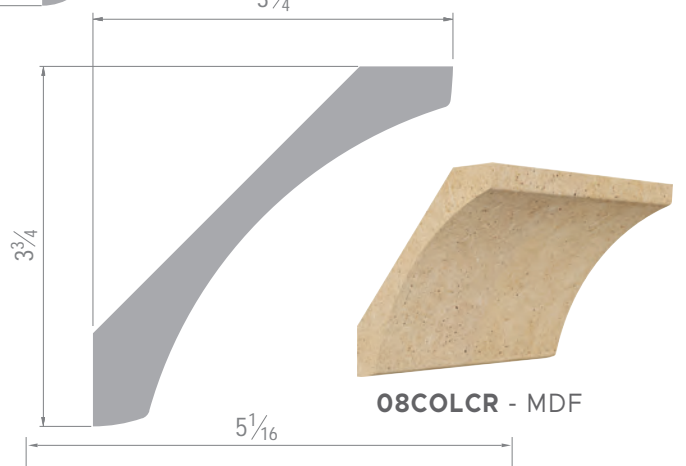

UWSPUL



# CR48



01CR48 - FJP



05CR48 - FLEX

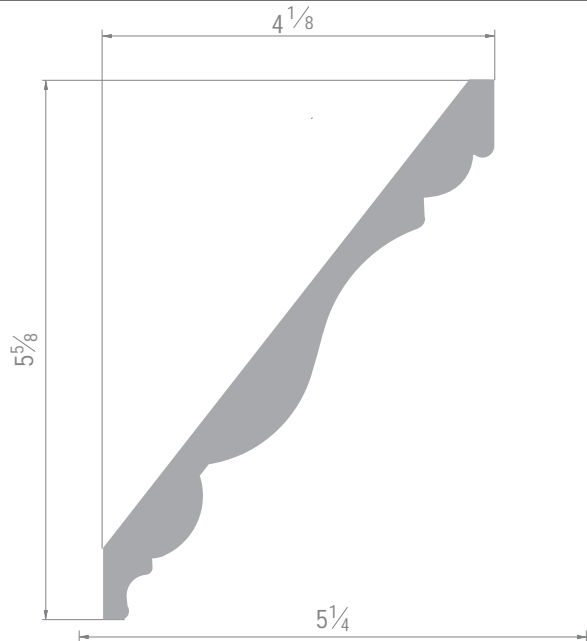

# 714COLCR



08714COLO - MDF

 BED

# UW72

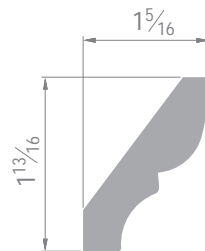

00072 - PIN



UW74

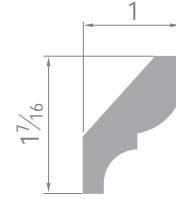

**0074 - PIN**



**88074 - RO**



**04074 - PFJ**



**01074 - FJP**

UW70

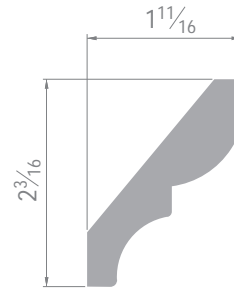

**00070 - PIN**

UW85

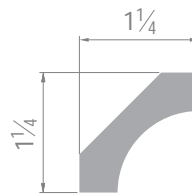

**00085 - PIN**

# UW93

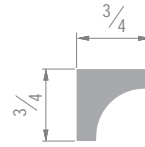

**85093** - MP



**88093** - RO



**00093** - PIN



**86093** - HK



**89093** - POP



**87093** - WO



# CABINET



**Are used to frame wall paneling and add accent to your walls. Often used in furniture construction .**



# PM5

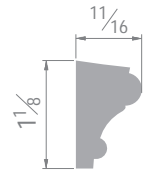

007105 - PIN



887405 - RO



857105 - MP



057105 - FLEX



777105 - KA



877105 - WO



017105 - FJP

# KPANEL

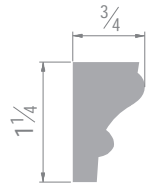

007114 - PIN



887114 - RO



777104 - KA



057104 - FLEX

# PM1

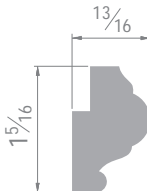

007101 - PIN



887101 - RO



857101 - MP



057104 - FLEX



017101 - FJP



# PM7

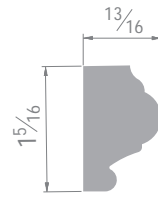

**007101** - PIN



**887101** - RO



**777101** - KA



**057701** - FLEX



**017101** - FJP



**857101** - MP

# UW134

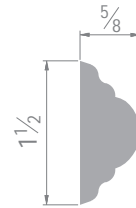

**00134** - PIN



**88134** - RO



**01134** - FJP



**05134** - FLEX

# PM2

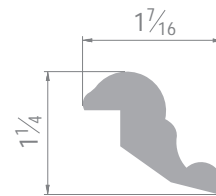

**007102** - PIN



**017102** - FJP



**057102** - FLEX

# PM6



007106 - PIN



887106 - RO



777106 - KA

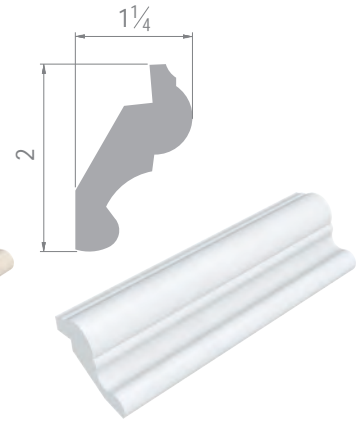

057106 - FLEX



017106 - FJP



857106 - MP

# LIP MOULD

## DEC2

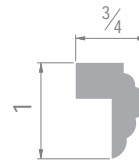

007110 - PIN

## DEC3

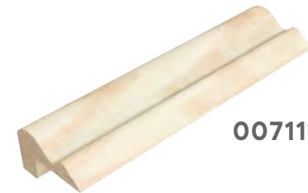
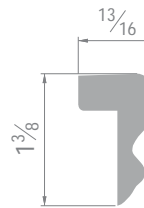

007111 - PIN

## DEC4

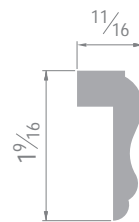

887112 - RO



007112 - PIN



## DEC6



**007113** - PIN



**887113** - RO



**017113** - FJP

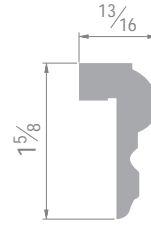

## DEC6FP

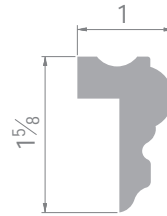

**017114** - FJP

## CM20

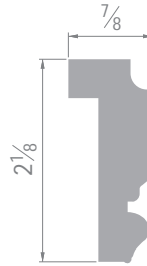

**007116** - PIN

## DEC7



**007117** - PIN



**887117** - RO



**017117** - FJP

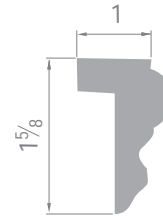

## CM12



**007115** - PIN

# WALL



Are used applied to a wall, they protect walls from sliding furniture. Used also as panel mouldings to trim the tops of panels on walls or ceiling.

CR5



017005 - FJP

CR7

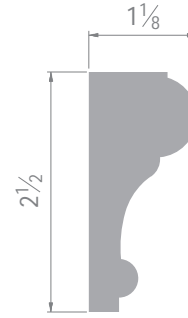

887007 - RO



057007 - FLEX



017007 - FJP



007001 - PIN

CM30

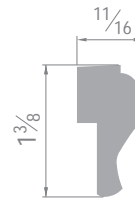

007118 - PIN

DM22

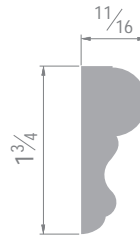

017119 - FJP

SM34

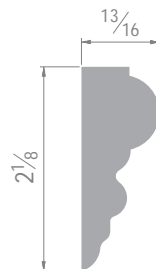

007120 - PIN

## CR6



**007006** - PIN



**057006** - FLEX

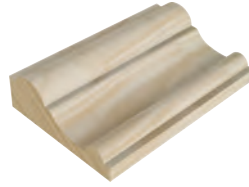

**017006** - FJP

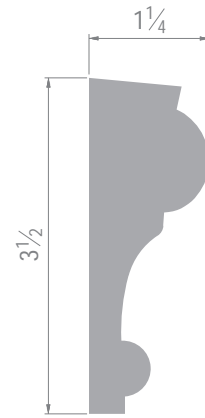

## UW297



**08297** - MDF

## UW390



**00390** - PIN



**08390** - MDF

## UW163

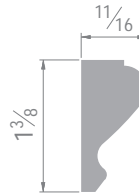

**00193** - PIN

## BATTEN

## UW224

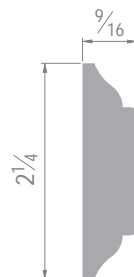

**00224** - PIN





# INSIDE AND OUTSIDE CORNERS

## UW206

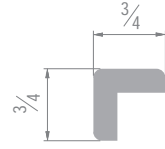

**00206 - PIN**

## UW205

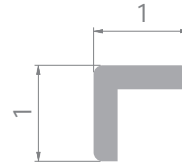

**88205 - RO**



**05205 - FLEX**



**00205 - PIN**

## UW204

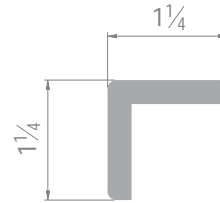

**88204 - RO**



**04204 - PFJ**



**00204 - PIN**



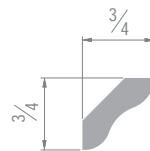

## UW999



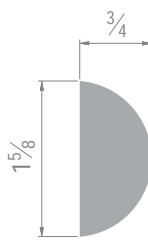

**00999 - PIN**

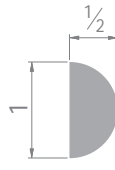



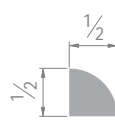

<p>UW116</p> <hr/>		 <p><b>00116 - PIN</b></p>
<p>UW120</p> <hr/>		 <p><b>00120 - PIN</b></p>

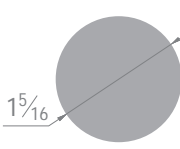

 QUARTER ROUND

<p>UW120</p> <hr/>		 <p><b>00108 - PIN</b></p>
--------------------	--	--

 FULL ROUND

<p>UW233</p> <hr/>		 <p><b>002233 - PIN</b></p>
--------------------	--	--

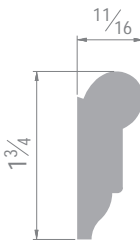
 PICTURE MOULD

<p>UW273</p> <hr/>		 <p><b>00273 - PIN</b></p>
--------------------	--	---



# GENERAL PURPOSE



**Are used for a multitude of purpose including shelving, window liner, base, casing, etc.**

# UW248

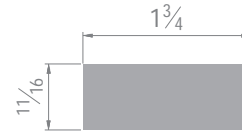

04248 - PFJ



00248 - PIN



01248 - FJP

# 1X2

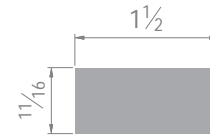

041x2 - PFJ



891x2 - POP



881x2 - RO



851x2 - MP



771x2 - KA



081x2 - MDF



01x2 - FJP

# 1X4

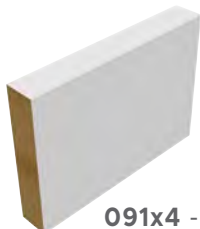
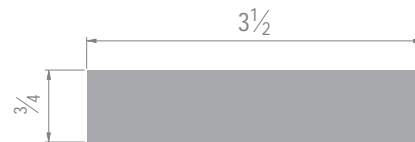

091x4 - PMD



851x4 - MP



771x4 - KA



081x4 - MDF



051x4 - FLEX



041x4 - PFJ



011x4 - FJP



# 1X6

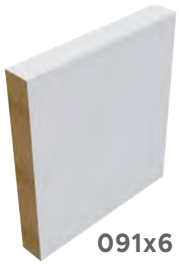
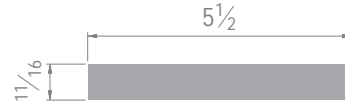

**091x6** - PMD



**851x6** - MP



**771x6** - KA



**081x6** - MDF



**051x6** - FLEX



**041x6** - PFJ



**011x6** - FJP

# 1X8

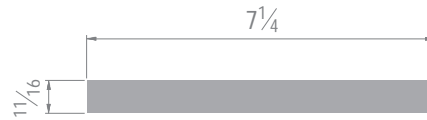

**091x8** - PMD



**851x8** - MP



**771x8** - KA



**081x8** - MDF



**051x8** - FLEX



**041x8** - PFJ



**011x8** - FJP



# 1X12

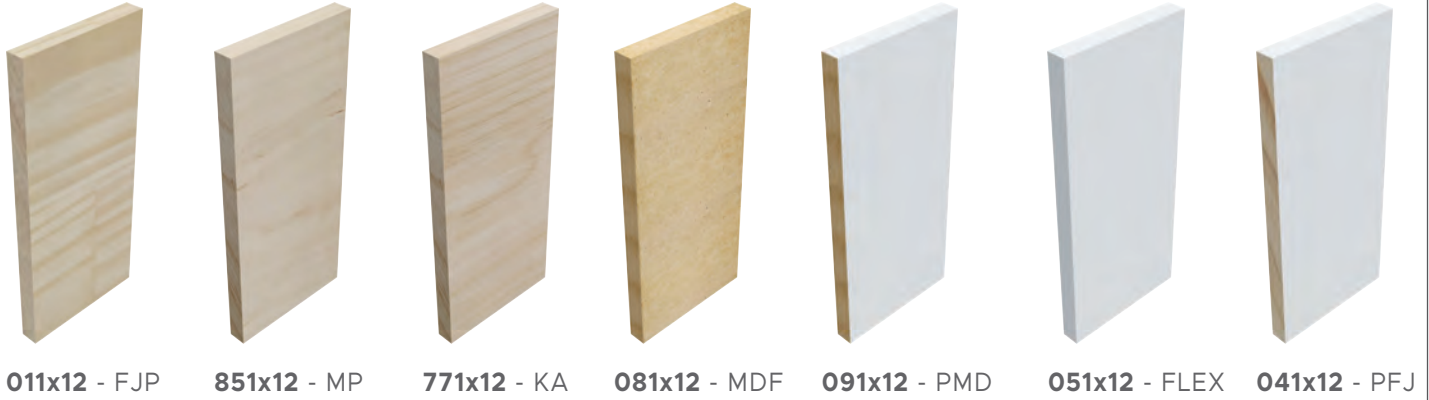
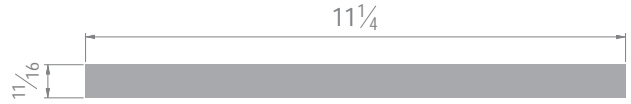

# 1X16

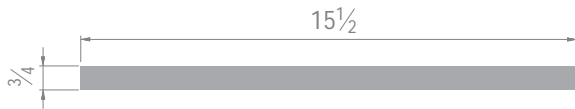

# 1X24

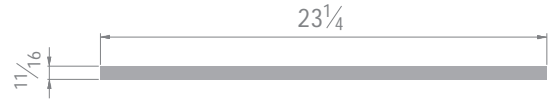

## LETTICE

# UW268

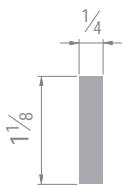

# UW267

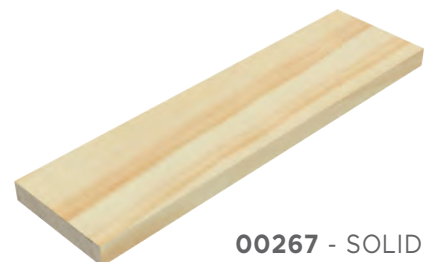
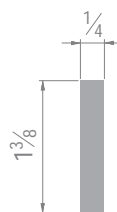

## UW266

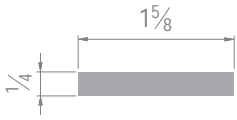

**00266 - SOLID**

## UW265

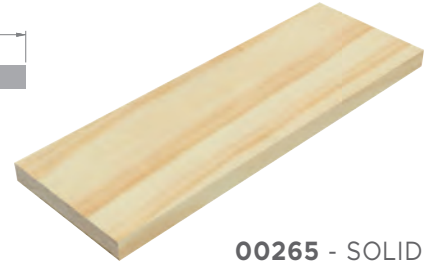
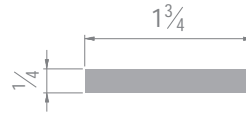

**00265 - SOLID**

## UW960

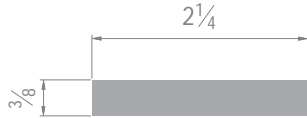

**00960 - SOLID**

## UW142

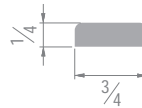

**00142 - SOLID**

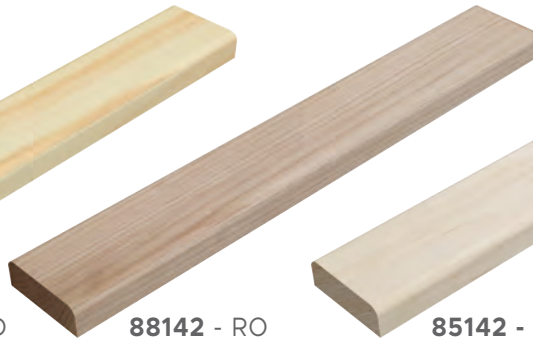

**88142 - RO**



**85142 - MP**



**77142 - KA**

UW995

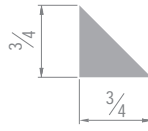

**00995 - SOLID**

 DRIP CAP

UW187

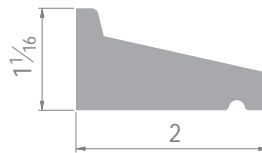

**00187 - SOLID**

 MANTLE MOULD

M-MMOULD

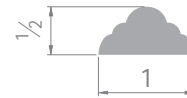

**007120 - SOLID**



**057120 - FLEX**

M-NMOULD



**007119 - SOLID**



# MI-MOULD

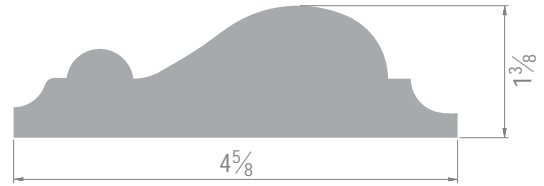

**007118** - SOLID



**057118** - FLEX



**017118** - FJP



# WINDOW DOOR



Are used primarily to cover the gap between drywall and the door or window frame.

# HWtD6E

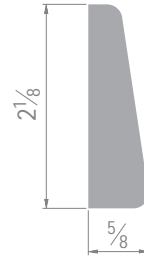

**01324 - FJP**



**04324 - PFJ**



**00324 - SOLID**

# UW324

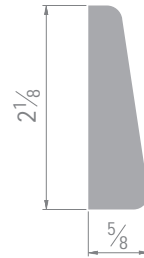

**01324 - FJP**



**04324 - PFJ**



**00324 - SOLID**

# C195



**0170295 - PFJ**

# C196

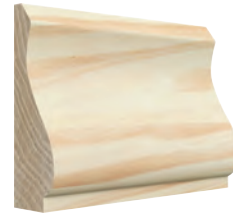

**007296 - SOLID**



**017296 - PFJ**

# C295



**007295 - SOLID**



**017295 - PFJ**



**057295 - FLEX**

# E212



**00212 - SOLID**



**04212 - PFJ**



**01212 - FJP**



# UW356



**01356 - FJP**



**04356 - PFJ**



**00356 - SOLID**



**08356 - MDF**



**88356 - RO**

# C100



# ACOL7301



**017301 - FJP**



**047301 - PFJ**



**057301 - FLEX**

# ACOL7302

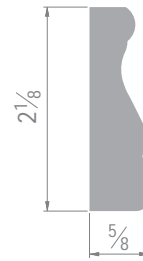

**017302 - FJP**



**047302 - PFJ**



**00302 - SOLID**



**08302 - MDF**

# ACOL7303



**057303 - FLEX**



**007303 - SOLID**



**0473030 - PFJ**



**0873030 - MDF**



**887303 - RO**



**0173030 - FJP**



**777303 - KA**



# ACOL7304



**057304 - FLEX**



**007304 - SOLID**



**017304 - FJP**



**047302 - PFJ**

# ACOL7305

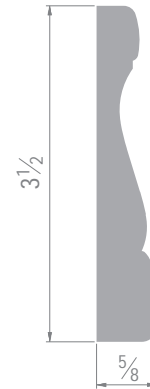

**057305 - FLEX**



**007305 - SOLID**



**017305 - FJP**



**777305 - KA**



**887305 - RO**



**047305 - PFJ**

# MC9

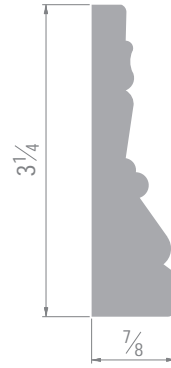

**00MC9 - SOLID**



**04MC9 - PFJ**

# CR211



**057211 - FLEX**



**017211 - FJP**



**007211 - SOLID**

# LC11



**887311 - RO**



**777311 - KA**



**107311 - FJP**



**087311 - PMD**



**057311 - FLEX**



**047311 - PFJ**



**007311 - PIN**



C11

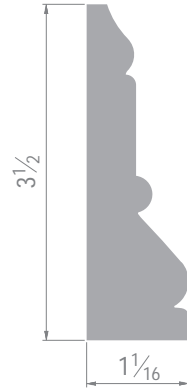

107511 - FJP



007511 - PIN

C322



007522 - PIN



087522 - PMD



777522 - KA



107522 - FJP



857522 - MP



057522 - FLEX



047522 - PFJ

C22



007422 - PIN



107422 - FJP



# C522



**887522 - RO**



**777522 - KA**



**107522 - FJP**



**057522 - FLEX**



**047522 - PRI**



**007522 - PIN**

# UW1

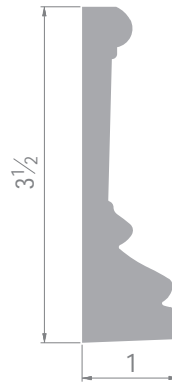

**100217 - FJP**

# CSTEP214



**002205 - PIN**



# LA314

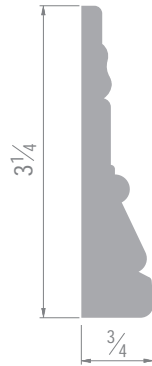

**047314 - PFJ**



**007314 - PIN**

# FLR

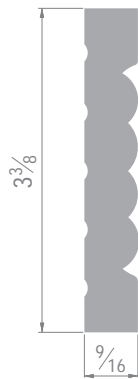

**080547 - PMD**

# FLUTE3



**107373 - FJP**



**007373 - PIN**



**087373 - PMD**



**057373 - FLEX**



**047373 - PFJ**



# FLUTE5

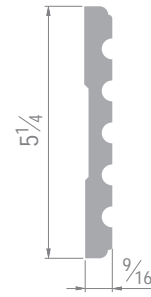

**107375** - FJP



**047375** - PFJ



**007375** - PIN

 DOORSTOP

# UW887



**10887** - FJP



**04887** - PFJ



**00887** - PIN



# UW876



**88876 - RO**



**77876 - KA**



**40876 - PFJ**



**10876 - FJP**



**00876 - PIN**

# UW906

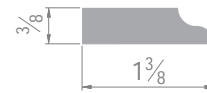

**00906 - PIN**



**10906 - FJP**



**04906 - PFJ**

# UW175

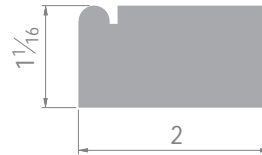

**10L175 - FJP**



**00L175 - PIN**



**04L175 - PFJ**

# LUW175

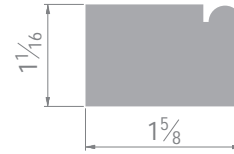

**10L175 - FJP**



**04L175 - PFJ**



**04L175 - PIN**

# UW180

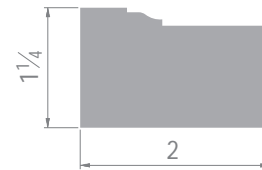

**00180 - PIN**



**10180 - FJP**



**04180 - PFJ**



**05180 - FLEX**



**77180 - KA**

## WINDOWS STOOL

# UW10215

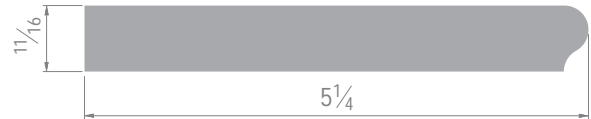

**1010215 - FJP**



**0810215 - PMD**



**0010215 - PIN**



**0410215 - PJF**



## UW10216

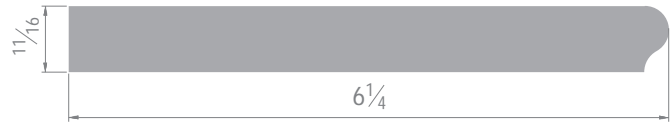

**1010216** - FJP



**0810216** - PMD



**0010216** - PIN



**0410216** - PFJ

## UW10217

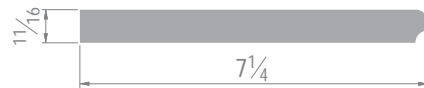

**1010216** - FJP

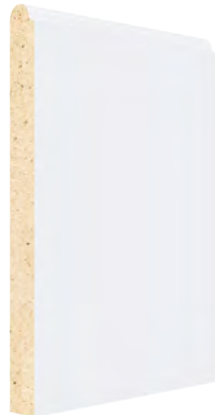

**0810216** - PMD



**0010216** - PIN

## UW10217D

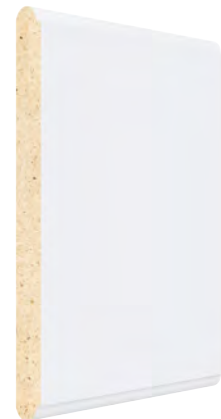
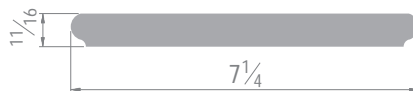

# UW10216

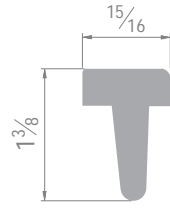

001315 - PIN

# UWTEX

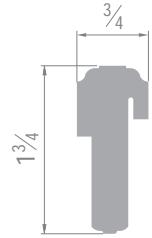

77334 - KA



10334 - FJP



04334 - PFJ



00334 - PIN



# FLOOR



**Are placed along the wall at the floor. They should be chosen to work in harmony with your casing to finish and tie the room together. Baseboard are usually thinner than the casing.**





SAN BASE

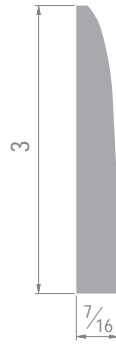

107724 - FJP



047724 - PFJ



007724 - PIN



UW713

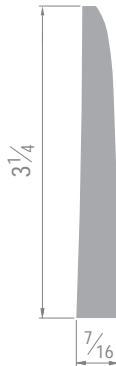

10713 - FJP



00713 - PIN



E BASE



107312 - FJP



047312 - PRJ



007312 - PIN





K314

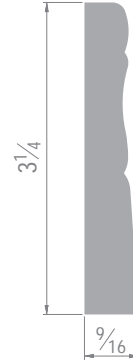

**107643 - FJP**



**047643 - PRJ**



**007643 - PIN**



**887643 - RO**



UW444

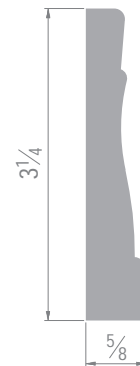

**10444 - FJP**



**08444 - PMD**



**00444 - PIN**



**04444 - PFJ**

ACOL7603



**017603 - FJP**



**057603 - FLEX**



**007603 - PIN**



**047603 - PRJ**



UW3041



**103041 - FJP**



**003041 - PIN**

N314

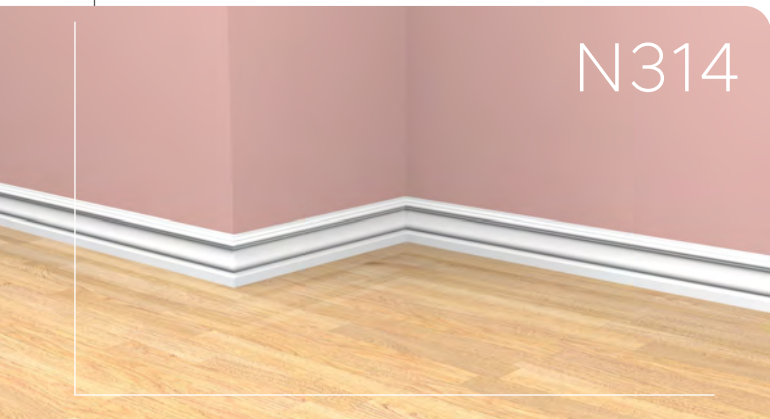

**08305 - PMD**





UWSTEP



**00STEP** - PIN

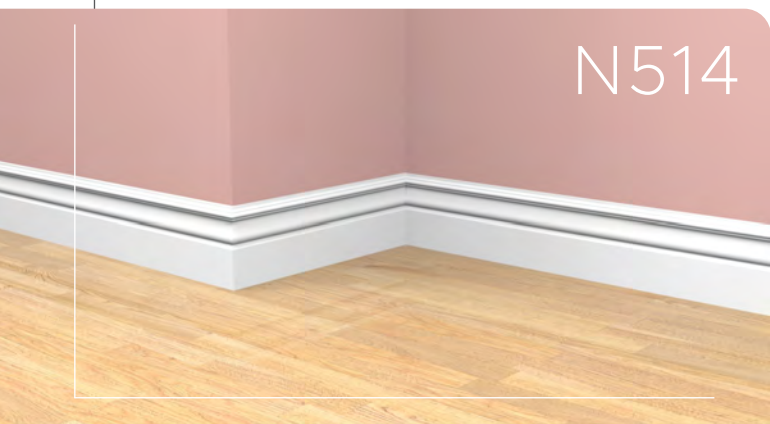

N514



**008318** - PMD



ACOL7601



**107601** - FJP



**057301** - FLEX



**007601** - PIN



**047601** - PFJ



B3

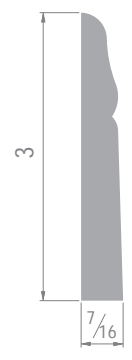

107612 - FJP



057612 - FLEX



047612 - PFJ

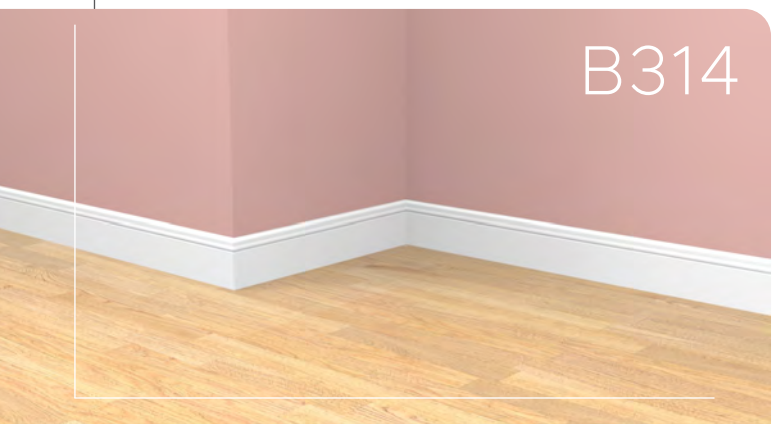

B314

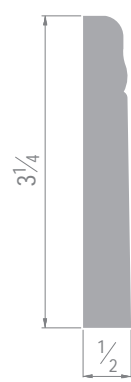

107613 - FJP



047613 - PFJ



057613 - FLEX



007613 - PIN



087613 - PMD





B218



**77218 - KA**



**05218 - FLEX**



**10218 - FJP**



**08218 - PMD**



**047218 - PFJ**



**00218 - PIN**

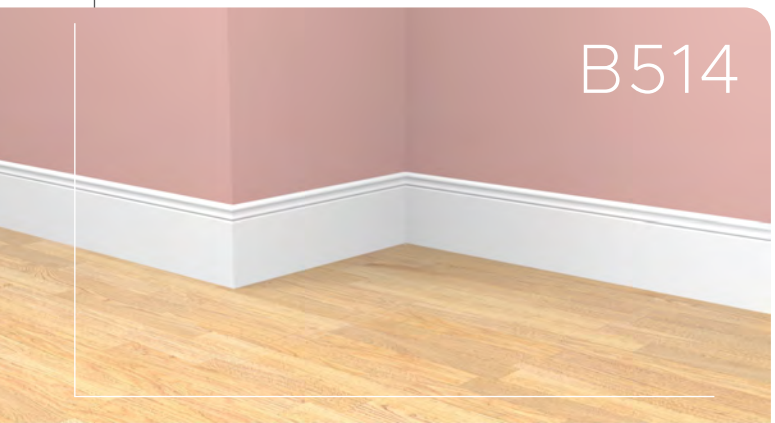

B514

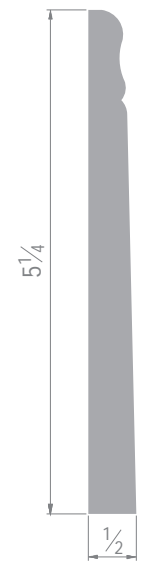

**007615 - PIN**



**057615 - FLEX**



**107615 - FJP**



**047615 - PFJ**

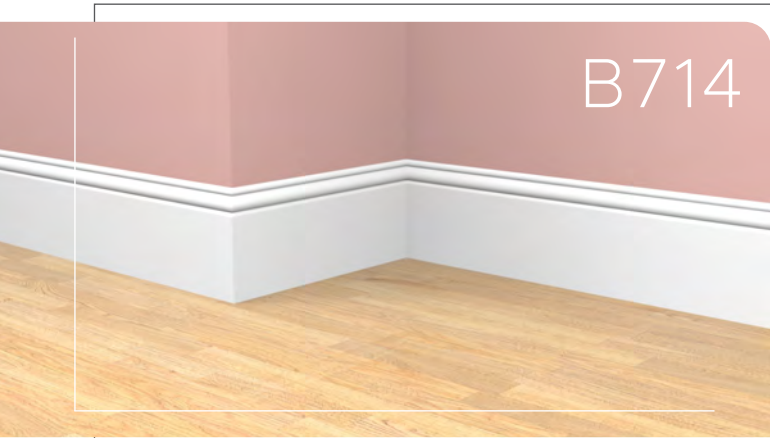

B714

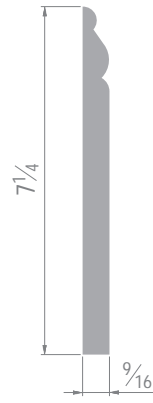

087318 - PMD



UW511



08511 - PMD



04511 - PFJ



UW623



00623 - PIN



08623 - PMD



04623 - PFJ



10623 - FJP





LB11

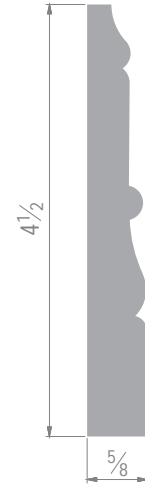

**047411 - PFJ**



**107411 - FJP**



**887411 - RO**



**007411 - PIN**



**087411 - PMD**



**057411 - FLEX**



UW620



**04620 - PFJ**



**05623 - FLEX**



**08623 - PMD**





LB11-5



047811 - PFJ



057811 - FLEX



107811 - FJP



UW618



04618 - PFJ

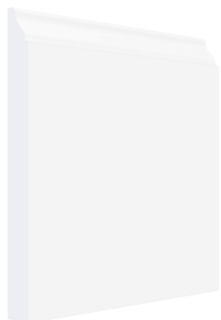

05618 - FLEX



10618 - FJP



08618 - PMD





B11

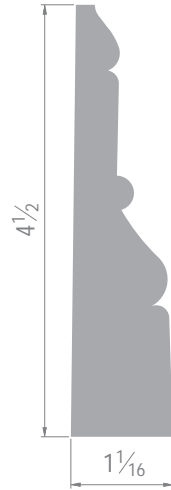

107711 - FJP



007711 - PIN



B211



007411 - PIN



057511 - FLEX



047411 - PFJ



107411 - FJP



B322



057622 - FLEX



087622 - PMD



107622 - FJP



777622 - KA



857622 - MP



887622 - RO



047622 - PFJ



007622 - PIN



BCOL3



057314 - FLEX



007314 - PIN



047314 - PFJ



107314 - FJP





BCOL5



**057514 - FLEX**



**047514 - PFJ**



**107514 - FJP**

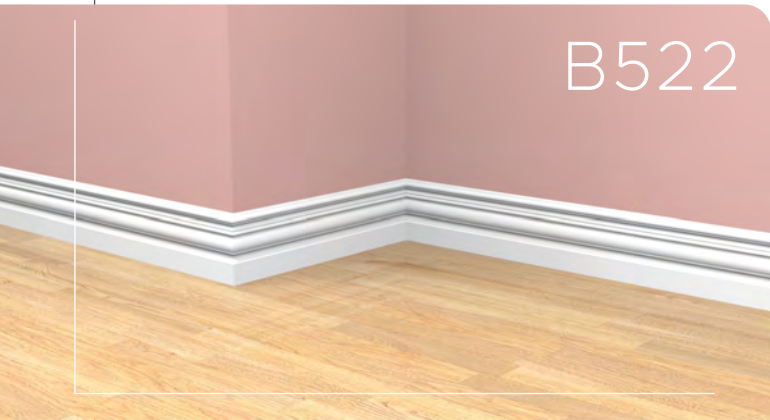

B522



**057822 - FLEX**



**007822 - PIN**



**107822 - FJP**



**777822 - KA**



**857822 - MP**



**047822 - PFJ**





B395



007395 - PIN



047395 - PRJ



107395 - FJP

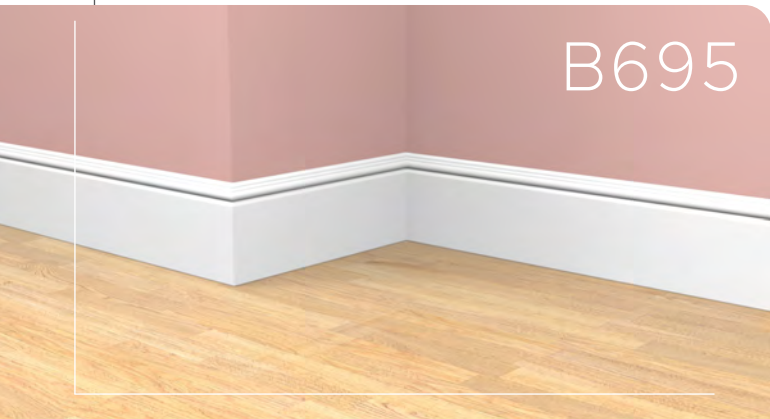
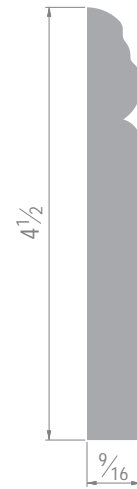

B695



007695 - PIN



047695 - PRJ



107695 - FJP



057695 - FLEX



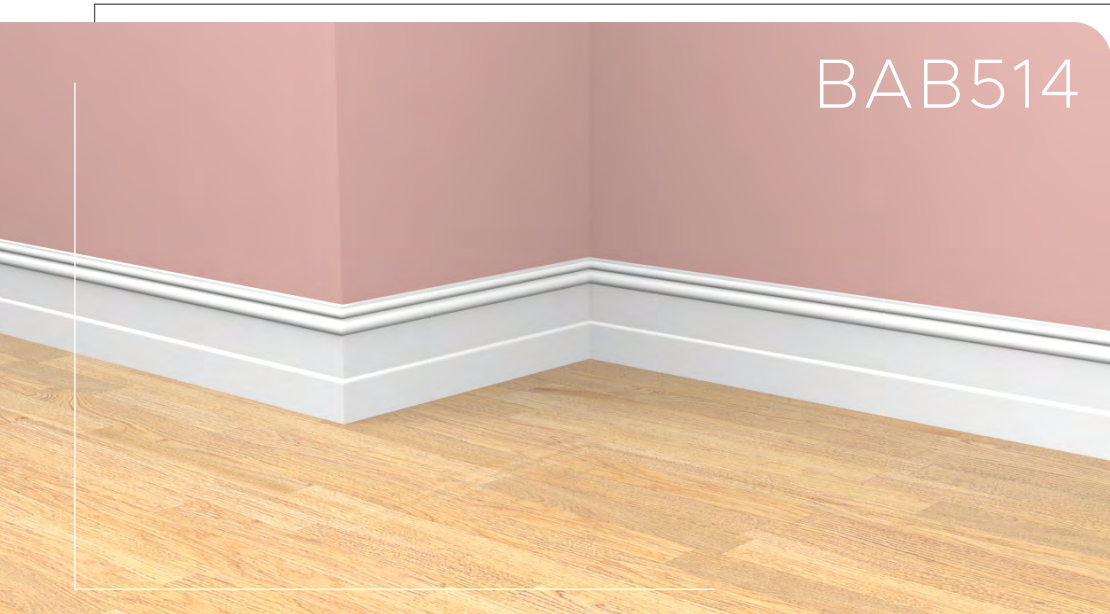

BAB514

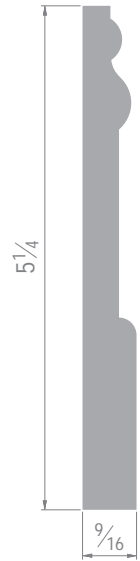

**04527 - PRJ**



**00527 - PIN**



**08527 - PMD**



**10527 - FJP**

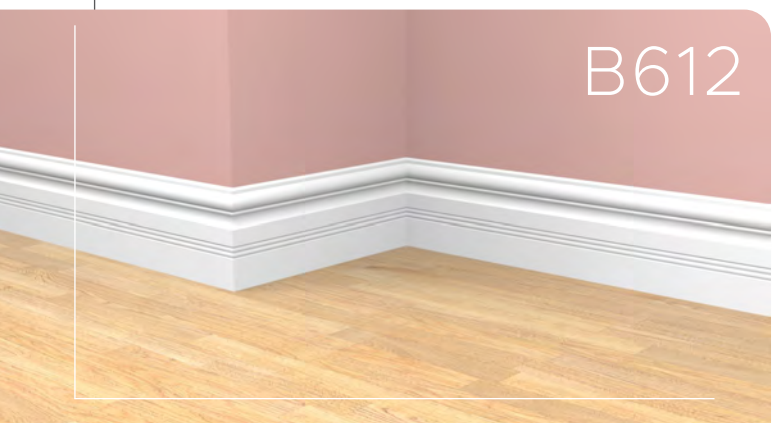

B612

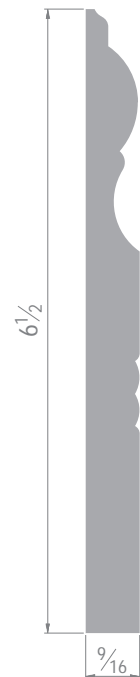

**08522 - PMD**



B22

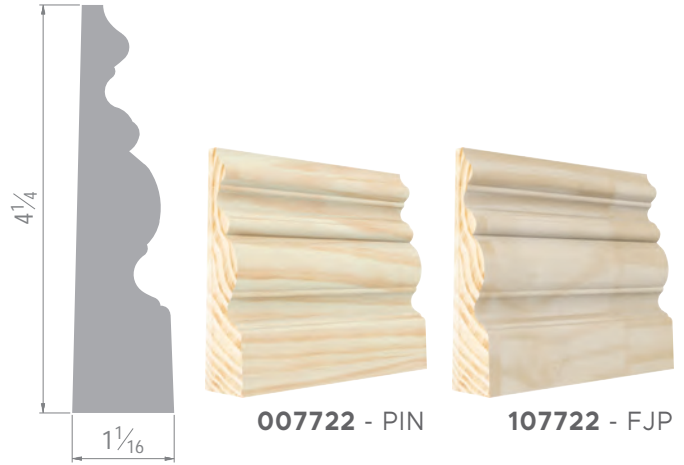

007722 - PIN

107722 - FJP



UW834



08834 - PMD



LA412



08549 - PMD





**004512 - PFJ**

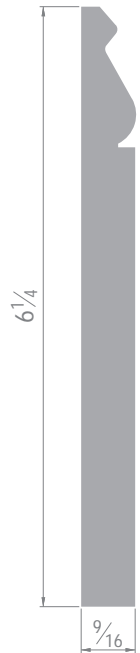

**004610 - PFJ**

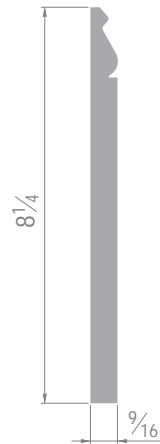

**004810 - PFJ**



QUALITY  
AND  
EXPERIENCE

---



**Thank you for considering Unique Wood  
Product as your moulding supplier. We whole  
heartedly cherish the relationship we have  
built over the years and appreciate a chance  
to earn your business and be able to keep as a  
long-lasting customer.**







Tel: (713) 462-5045

Fax: (713) 462-5086

[info@uniquewoodproducts.com](mailto:info@uniquewoodproducts.com)

[www.uniquewoodproducts.com](http://www.uniquewoodproducts.com)



**UNIQUE**

WOOD PRODUCTS



# UNIQUE

WOOD PRODUCTS

**INTERIOR MOULDING & TRIM**

